

RSFK2492F009C1

2.492 GHz BeiDou S Band Filter



Description

RSFK2492F009C1 is a miniature filter designed for BeiDou S band equipment. RSFK2492F009C1 is designed with advanced temperature-compensated Film Bulk Acoustic Resonator (FBAR) technology. Typical insertion loss in the pass band is 4dB. Rejection at the LTE and Wi-Fi band is more than 40dB.

Features

- ✧ For BeiDou S Band application
- ✧ Plastic Chip Scale Package(CSP)
- ✧ Miniature Size
 - 3 mm x 3 mm x 0.85 mm
- ✧ Low Insertion loss
- ✧ High rejection at LTE and Wi-Fi bands.
- ✧ Extremely Low Temperature Coefficient of Frequency (< 5 ppm/ °C)
- ✧ Excellent Power Handling Capability: 0.5 W
- ✧ Moisture Sensitivity:MSL3

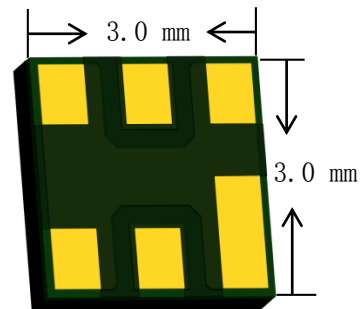

RSFK2492F009C1

2.492 GHz BeiDou S Band Filter



Electrical Specification

Operating Temperature range: -40 to +85°C

Parameter	Min	Typ	Max	Unit
Center Frequency	2492			MHz
Insertion Loss(2488 ~ 2496 MHz)	\	4	5	dB
Ripple(2488 ~ 2496 MHz)	\	1	1.5	dB
Return Loss(2488 ~ 2496 MHz)	10	15	\	dB
Absolute Attenuation	\			
1000~2470 MHz	40	42	\	dB
2470~2480 MHz	10	20	\	dB
2510~2700MHz	40	45	\	dB
2700~3000MHz	35	40	\	dB

Typical Performance at Tc=25° C

Pass Band Response (S21)

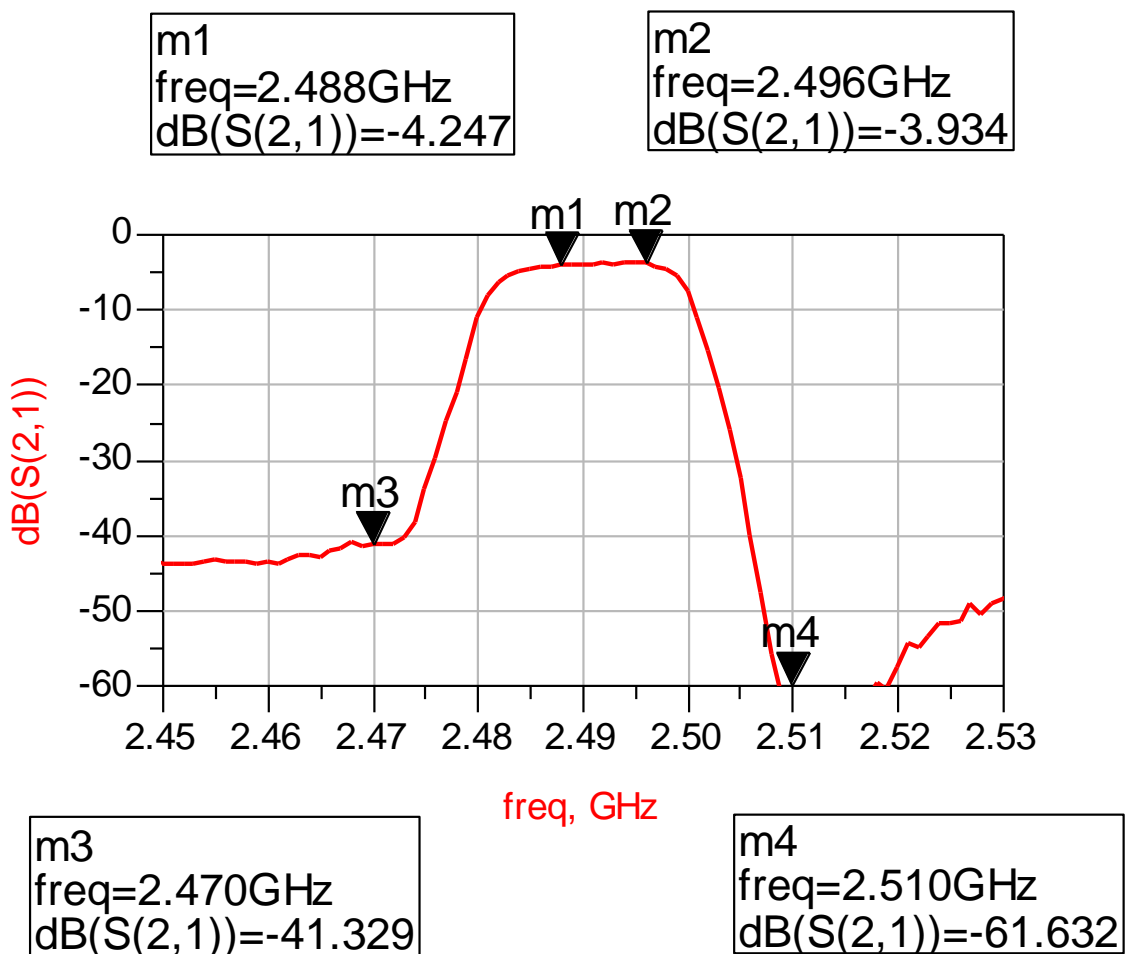

Pass Band Response (S22)

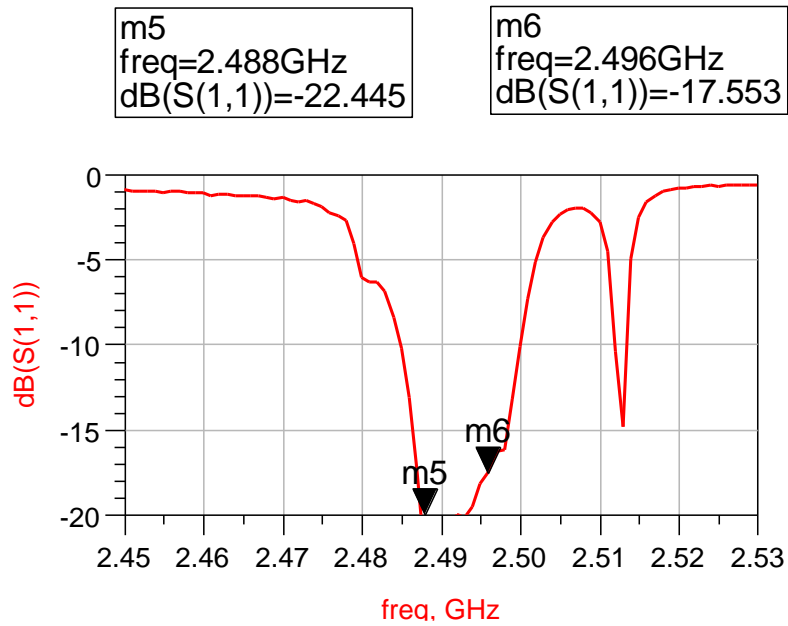

Wide Band Response (S21)

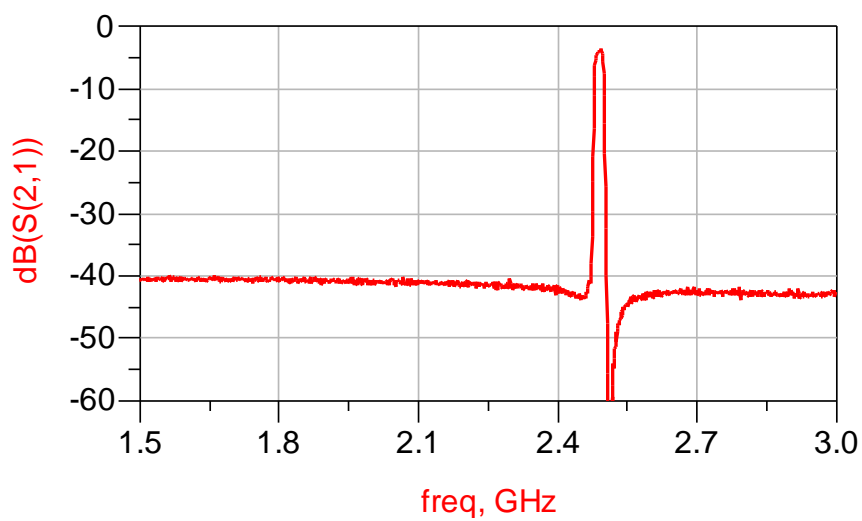

Pass Band Group Delay

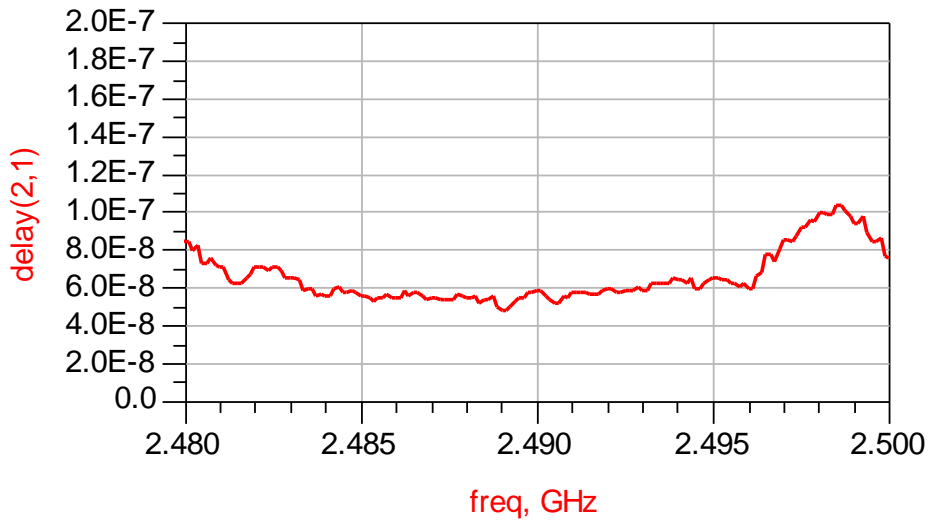

Over-Temperature Response

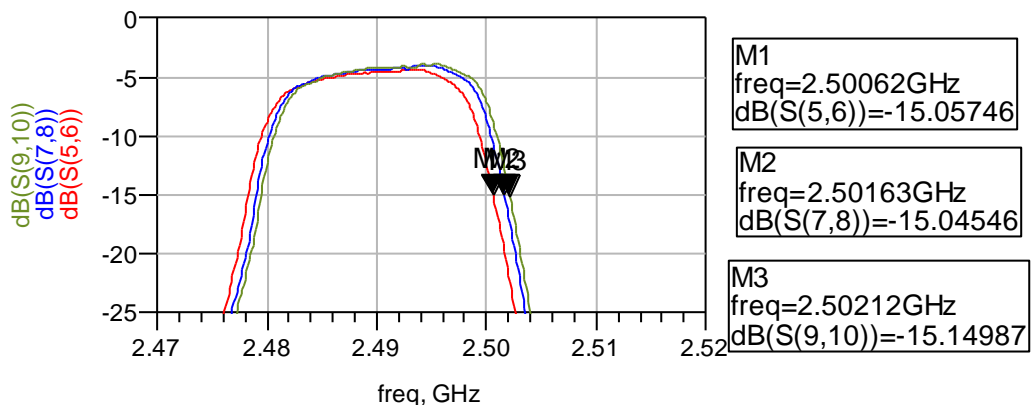

Red: -55C Performance
 Blue: 25C Performance
 Green: 85C Performance

RSFK2492F009C1

2.492 GHz BeiDou S Band Filter

Package Outline

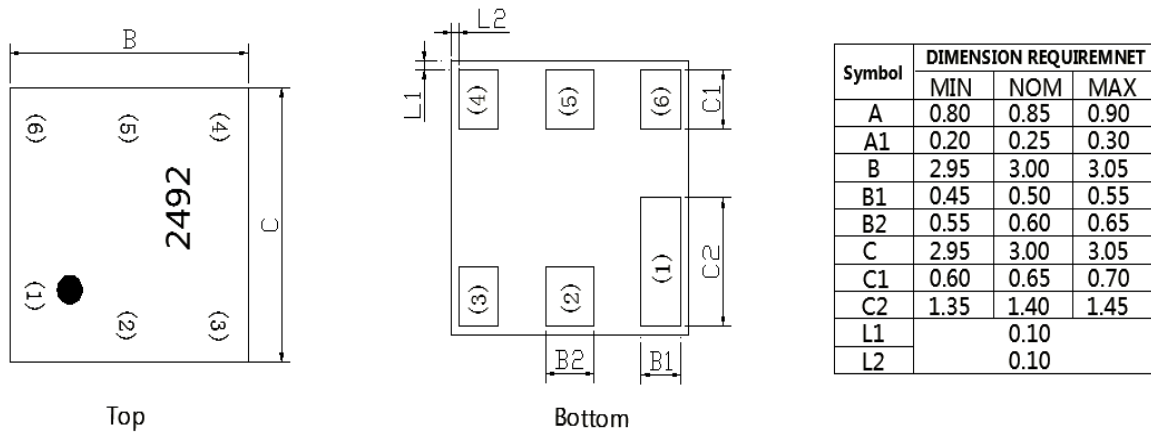

Notes:

- 1: Dimension: mm
- 2: Dimensions nominal unless otherwise noted
- 3: Contact area are gold plated
- 4: YY: Manufacture Year; WW: Manufacture week

Pin connection:

- 2 Input
- 5 Output
- 1,3,4,6 Ground



Side View

Packing

1. Tape Dimension

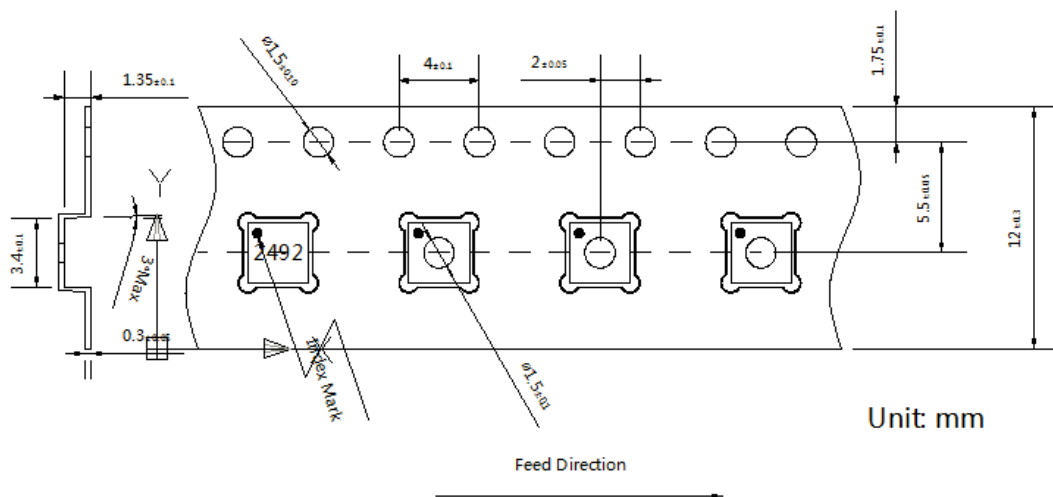

RSFK2492F009C1

2.492 GHz BeiDou S Band Filter

2. Reel Dimension

4000Pcs/Reel

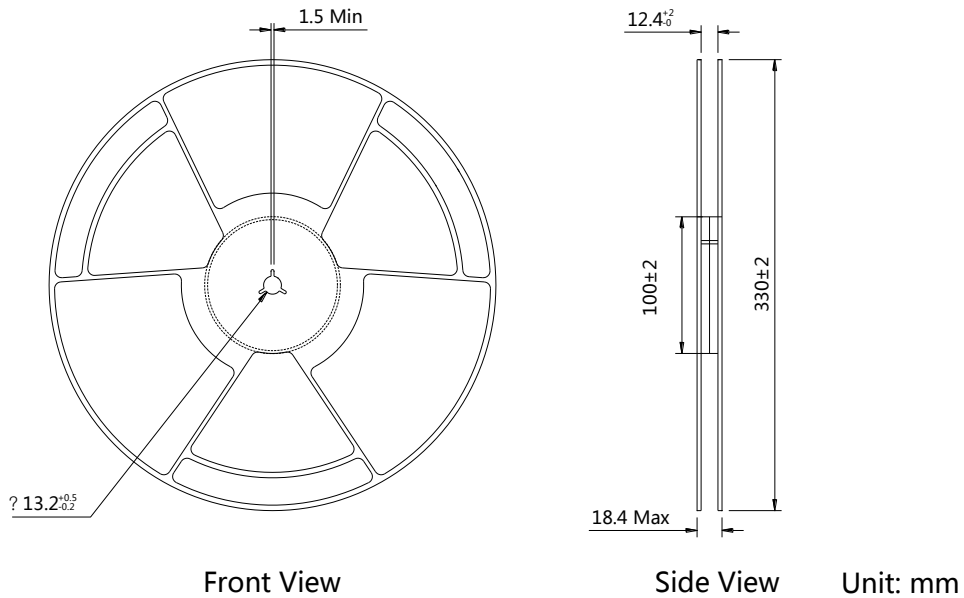

Recommended IR Reflow Profile

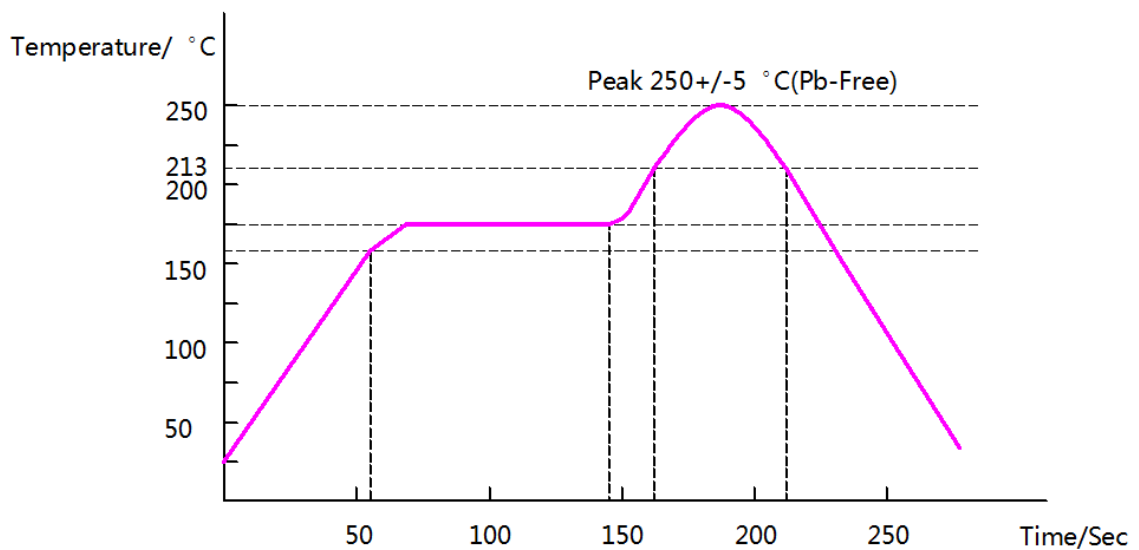

RSFK2492F009C1

2.492 GHz BeiDou S Band Filter



Order Information

Part Number	Qty Per Reel	Container
RSFK2492F009C1	4000	13 inch Reel

For more information, please contact: lizhuoyuan@megsine.com

Notes:

The specification may be changed or the product had been discontinued, please check with our sales or product engineer before order.